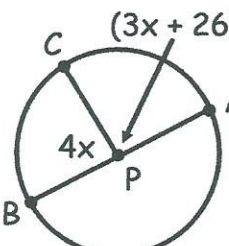
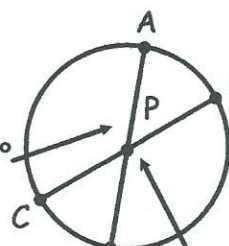
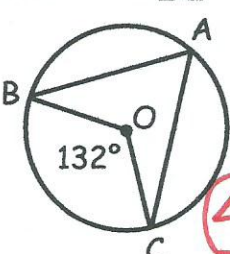

In 1-2, use $\square P$ to find the value of x . Then, find the arc measures.

1.  $4x + 3x + 26 = 180$
 $7x + 26 = 180$
 $7x = 154$
 $x = 22$
 $m\widehat{BC} = ?$ $4 \cdot 22 = \boxed{88}$
 $m\widehat{AC} = ?$ $3(22) + 26 = \boxed{92}$

 $4x - 5 = 2x + 65$
 $2x = 70$
 $x = 35$
 $m\widehat{AC} = ?$ $4(35) - 5 = \boxed{135}$
 $m\widehat{BD} = ?$ $2(35) + 65 = \boxed{135}$

Find the measure of the indicated arc or angle in $\square O$.

3. $m\angle BAC = ?$
 $\angle A = \frac{132}{2}$
 $\angle A = \boxed{66}$

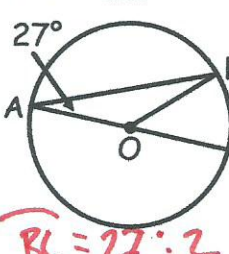
4. $m\widehat{BC} = ?$
 $\widehat{BC} = 27 \cdot 2$
 $\widehat{BC} = \boxed{54}$

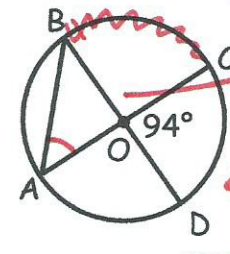
5. $m\angle BAC = ?$
 $180 - 94 = 86$
 $BC = 86$
 $\angle A = \frac{86}{2}$
 $\angle A = \boxed{43}$

Find the value of each variable.

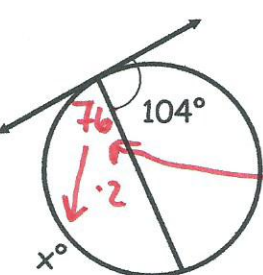
6.  $180 - 104 = 76$
 $x = 76 \cdot 2 = \boxed{152}$

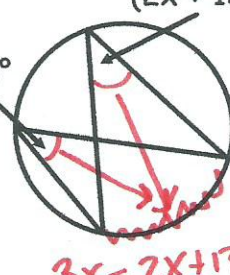
7.  $3x = 2x + 13$
 $x = \boxed{13}$

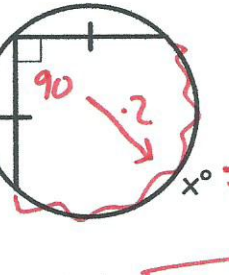
8.  $x = 180$
 $y = \frac{180}{2} = \boxed{90}$

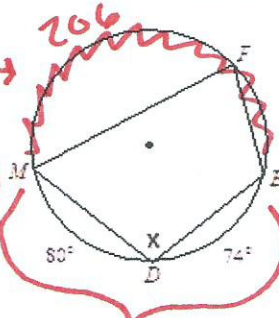
9.  $x = \frac{206}{2}$
 $x = \boxed{103}$

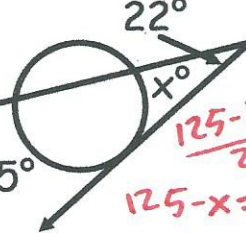
10.  $\frac{125 - x}{2} = 22$
 $125 - x = 44$
 $-x = -81$
 $x = \boxed{81}$

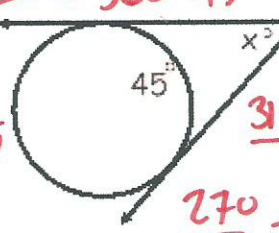
11.  $360 - 45$
 $\frac{315 - 45}{2} = x$
 $\frac{270}{2} = x$
 $x = \boxed{135}$

12. Find the area and arc length of the shaded region.

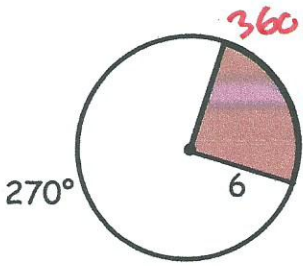

$$AL = \frac{\text{m}\widehat{\text{arc}}}{360} \cdot 2\pi r \rightarrow \frac{90}{360} \cdot 2\pi 6 = 3\pi \rightarrow 9.42$$

$$SA = \frac{\text{m}\widehat{\text{arc}}}{360} \cdot \pi r^2 \rightarrow \frac{90}{360} \cdot \pi 6^2 = 9\pi \rightarrow 28.27$$

13. The area of one piece of pizza is $9\pi \text{ in}^2$. The pizza is cut into eighths. Find the radius of the pizza pie.

$$\text{Area} = 9\pi \cdot 8 = 72\pi$$

$$A = \pi r^2 \rightarrow 72\pi = \pi r^2 \rightarrow 72 = r^2 \rightarrow \boxed{r = 8.49 \text{ in}}$$

14. The clock in our classroom has a radius of 9 inches. If it's 4:00, find the arc length and area of the sector for this time.

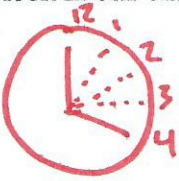

$$AL = \frac{1}{4} \cdot 2\pi r \rightarrow \frac{1}{4} \cdot 2\pi 9 \rightarrow 14.14 \text{ in} = AL$$

$$SA = \frac{1}{4} \cdot \pi r^2 \rightarrow \frac{1}{4} \cdot \pi 9^2 \rightarrow 63.62 \text{ in}^2 = SA$$

15. A triangular pyramid has equal side lengths of 2 feet. Its height is 3 feet. What is its volume?

$$A_{\text{PYR}} = \frac{B \cdot h}{3} \rightarrow \frac{1.7 \cdot 3}{3} = \boxed{1.7 \text{ ft}^3}$$

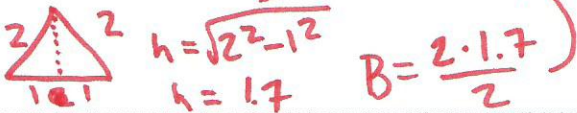

16. Weston has two round balloons. One balloon has a radius that is 3 times the radius of the other balloon. How much more air will the larger balloon need than the smaller balloon?

$$V_1 = \frac{4}{3} \pi r^3 \rightarrow \frac{4}{3} \pi r^3 \rightarrow \frac{4}{3} \pi r^3$$

$$V_2 = \frac{4}{3} \pi (3r)^3 \rightarrow \frac{4}{3} \pi 9r^3 \rightarrow \frac{4}{3} \pi r^3 \cdot 9 \rightarrow 9 \text{ times more air.}$$

17. Find the volume of the image below. (hint it is made of a cylinder and a half sphere)

$$V_{\text{cyl}} = \pi \cdot 50^2 \cdot 250 = 1963495.41$$

$$V_{\text{spn}} = \frac{4}{3} \pi 50^3 = \frac{523598.78}{2} = 261799.39$$

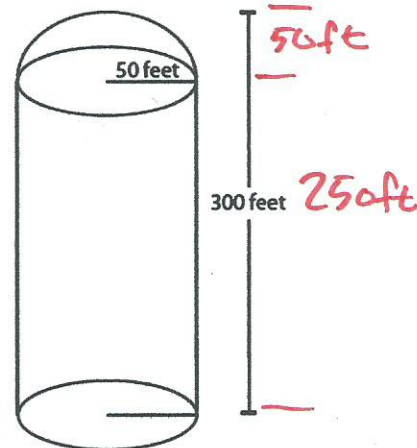

UNIT 5

- 1) If a line segment needs to be partition by a 2:5 ratio, what is the fraction that would be used in the formula to find the point?

$$\frac{2}{7}$$

- 2) Find the midpoint of the segment given the points $A(4, -3)$ and $B(-11, 8)$.

$$MP = \left(\frac{x_2 + x_1}{2}, \frac{y_2 + y_1}{2} \right)$$

$$\left(\frac{-11 + 4}{2}, \frac{8 + -3}{2} \right) \rightarrow \boxed{(-3.5, 2.5)}$$

Show/Explain how you know if the following lines are parallel, perpendicular or neither

- 3) $y = -\frac{3}{2}x - 10$ and $y = \frac{2}{3}x + 5$

Perpendicular
because the slopes
are opposite reciprocals
of each other

- 4) $x - y = 10$ and $-2x + 5y = 6$
- $$\begin{array}{r} +y \quad +y \\ x - y = 10 \\ -10 \\ \hline x = y + 10 \end{array}$$
- $$\begin{array}{r} +2x \quad +2x \\ -2x + 5y = 6 \\ +2x \\ \hline 5y = 2x + 6 \\ y = \frac{2}{5}x + \frac{6}{5} \end{array}$$

Neither, because slopes are different

- 5) Find Point Z that partitions the directed line segment XY by $\frac{1}{3}$ from X, where $X(-4, 8)$ and $Y(-10, -2)$.

Graph.

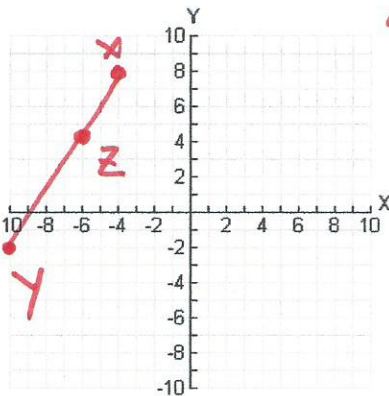

$$\Delta x = -6 \cdot \frac{1}{3} = -2$$

$$\Delta y = -10 \cdot \frac{1}{3} = -3.3$$

$$\boxed{(-4 - 2, 8 - 3.3)}$$

$$\boxed{(-6, 4.7)}$$

- 6) ABCD has vertices at $A(-6, -6)$, $B(-4, 1)$, $C(1, 1)$. What point would D have to be for the figure to be a rectangle? Prove, mathematically, that this is a rectangle.

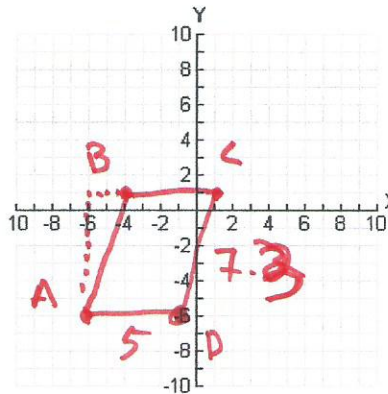

There is no point because $\angle ABC$ is not a right angle so a rectangle can not be formed

Also find the perimeter and are of the rectangle.

Perimeter = 24.6 Area = 35

Use $3x^2 + 3y^2 - 36x + 24y + 9 = 0$ for questions 7-10.

7) Put into standard form, find center & radius in simplest form.

$$x^2 - 12x + 36 + y^2 + 8y + 16 = -9 + 36 + 16$$

$$\frac{-12}{2} = -6^2 = 36 \quad \frac{8}{2} = 4^2 = 16$$

$$(x-6)^2 + (y+4)^2 = 43$$

10) Now use a protractor to accurately graph.

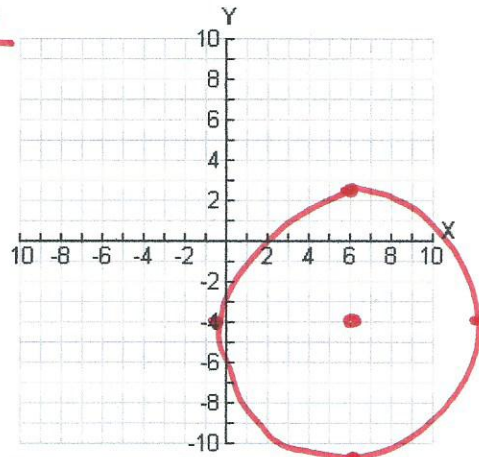

8) Center: $(6, -4)$

9) Radius: 6.56

Find the perimeter and area ($b \cdot h$) of the parallelogram below.

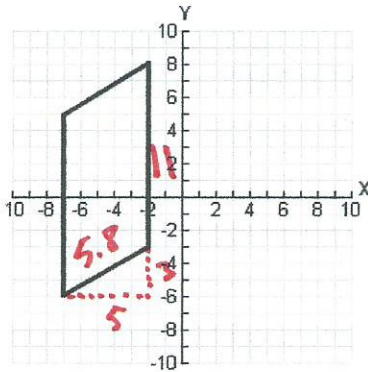

11) Perimeter: 33.6

12) Area: 55

13. Graph $x^2 + (y-3)^2 = 30$

$$C = (0, 3)$$

$$r = 5.5$$

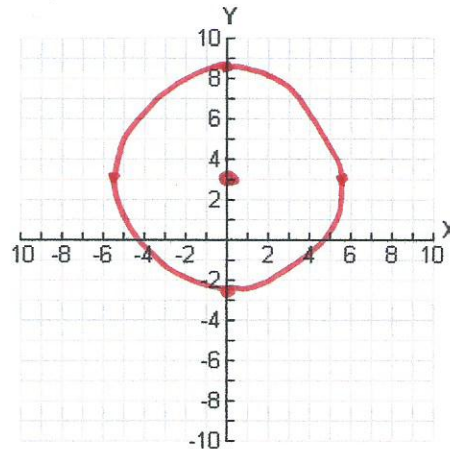

Unit 6

Use the following table to answer 14.

The table shows the number of endangered and threatened animal species in the United States as of November 30, 1998.

	Mammals	Birds	Reptiles	Amphibians	Other
Endangered	59	75	14	9	198
Threatened	8	15	21	7	69

14. Find the probability that a listed animal is endangered given that it is a reptile.

$$\frac{14}{35} = .4$$

A. $P(R | E) = 7\%$

B. $P(E \cap R) = 4\%$

C. $P(E | R) = 67\%$

D. $P(E | R) = 40\%$

Use the following table to answer 15 – 18.

On April 15, 1912, the Titanic struck an iceberg and rapidly sank with only 710 of her 2,204 passengers and crew surviving. Data on survival of passengers are summarized in the table below. (Data source: <http://www.encyclopedia-titanica.org/titanic-statistics.html>)

	Survived	Did not Survive	Total
First class passengers	201	123	324
Second class passengers	118	166	284
Third class passengers	181	528	709
Total passengers	500	817	1317

15. If one of the passengers is randomly selected, what is the probability that he/she was in first class?

A. $P(FC) = \frac{201}{324}$

B. $P(FC) = \frac{123}{1317}$

C. $P(FC) = \frac{324}{1317}$

D. $P(FC) = \frac{324}{709}$

$$\frac{324}{1317} = .246$$

16. If one of the passengers is randomly selected, what is the probability that this passenger survived?

A. $P(S) = \frac{500}{1317}$

B. $P(S) = \frac{201}{500}$

C. $P(S) = \frac{500}{817}$

D. $P(S) = \frac{817}{1317}$

$$\frac{500}{1317} = .379$$

17. If one of the passengers is randomly selected, what is the probability that this passenger was in first class and survived?

S

A. $P(FC \cap S) = \frac{201}{324} \approx 0.620$

B. $P(FC \cap S) = \frac{324}{1317} \approx 0.246$

C. $P(FC \cap S) = \frac{324}{500} \approx 0.648$

D. $P(FC \cap S) = \frac{201}{1317} \approx 0.153$

$$\frac{201}{1317} = .153$$

FC ∩

18. What is the probability that a randomly selected passenger survived, given that the passenger was in first class?

A. $P(S|FC) = \frac{201}{500} \approx 0.402$

B. $P(FC \cap S) = \frac{201}{500} \approx 0.402$

C. $P(S|FC) = \frac{201}{500} \approx 0.402$

D. $P(S|FC) = \frac{201}{324} \approx 0.620$

S |

FC

$$\frac{201}{324} = .62$$

Use the following to answer 19-20.

Given $P(A) = .72$, $P(B) = .29$, and $P(A \cup B) = .8012$.

19. Find $P(A \cap B)$.

- A. 0.2088
- B. 0.5924
- B. 0.4076
- D. 0.3837

$$P(A) + P(B) - P(A \cap B) = P(A \cup B)$$

$$.72 + .29 - ? = .8012$$

$$? = .2088$$

20. Determine if A and B are independent events.

- A. Yes, because $P(A \cap B) = P(A) \times P(B)$
- B. Yes, because $P(A \cup B) = P(A) \times P(B)$
- C. No, because $P(A \cap B) \neq P(A) \times P(B)$
- D. No, because $P(A \cup B) \neq P(A) \times P(B)$

$$P(A) \cdot P(B) = P(A \cap B) \quad .72 \cdot .29 = .2088$$

Independent \checkmark $.2088 = .2088$

21. In a bowl of m & m's, there are 12 red ones, 6 green ones, and 15 blue ones.

a. If two m&m's are chosen at random with replacement, what is the probability of picking a red m&m and then, a blue m&m?

$$\frac{12}{33} \cdot \frac{15}{33} = \frac{20}{121} \rightarrow .165$$

b. If three m&m's are chosen at random without replacement, what is the probability that they all three are green ones?

$$\frac{6}{33} \cdot \frac{5}{32} \cdot \frac{4}{31} = .004$$

22. A person rolls two dice, one after the other. Find the probability of the following events.

a. $P(\text{sum of 7 or sum of 10})$

$$\frac{6}{36} + \frac{3}{36} = \frac{9}{36} \rightarrow .25$$

b. $P(\text{odd sum or sum more than 5})$

$$\frac{18}{36} + \frac{26}{36} - \frac{12}{36} = \frac{32}{36} = .889$$

	1	2	3	4	5	6
1	2	3	4	5	6	7
2	3	4	5	6	7	8
3	4	5	6	7	8	9
4	5	6	7	8	9	10
5	6	7	8	9	10	11
6	7	8	9	10	11	12

23. Given the Venn Diagram below with set A and set B determine the following:

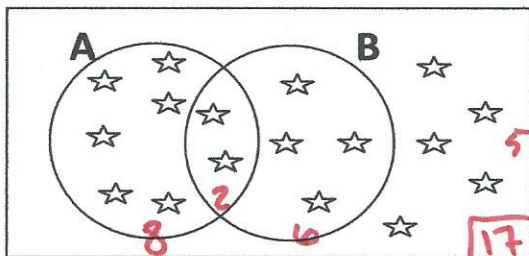

- a) $P(A) = \frac{8}{17}$
- b) $P(\overline{A \cup B}) = \frac{5}{17}$
- c) $P(A \cap B) = \frac{2}{17}$
- d) $P(A \cup B) = \frac{12}{17}$
- e) $P(\overline{A} \cup B) = \frac{9}{17}$
- f) $P(A \cap \overline{B}) = \frac{6}{17}$